

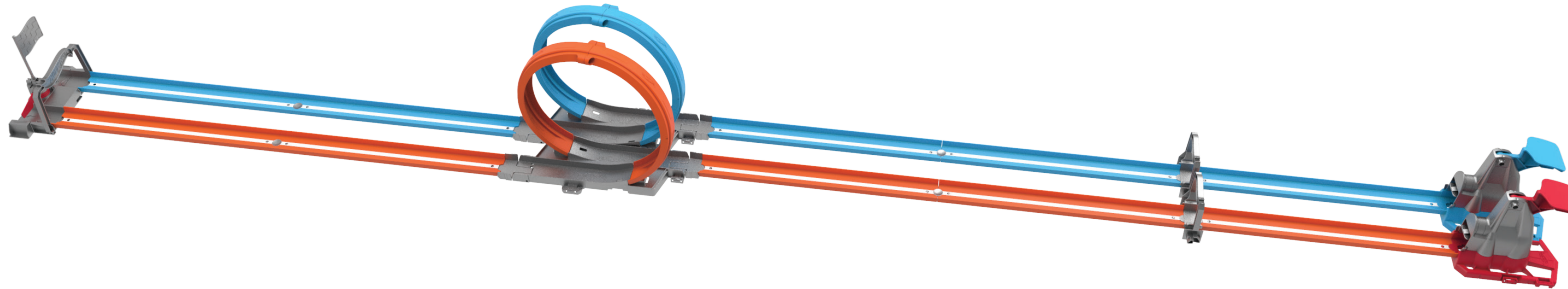

INSTRUCTIONS

DOUBLE LOOP DASH™



5-10

service.mattel.com

HOTWHEELS.COM

[? service.mattel.com](http://service.mattel.com)

COLORS AND DECORATIONS MAY VARY.

TWO VEHICLES INCLUDED. ADDITIONAL VEHICLES SOLD SEPARATELY.

NOT FOR USE WITH SOME HOTWHEELS® VEHICLES.



GFH85_0970

1102053424_DOM

PLEASE KEEP THESE INSTRUCTIONS FOR FUTURE REFERENCE AS THEY CONTAIN IMPORTANT INFORMATION.

©2018 Mattel. Mattel, Inc., 636 Girard Avenue, East Aurora, NY 14052, U.S.A. Consumer Services 1-800-524-8697 or 1-877-219-8335 (for products that can be controlled by smart devices). Mattel U.K. Ltd., Vanwall Business Park, Maidenhead SL6 4UB. Helpline 01628 500303. Mattel Australia Pty., Ltd., Richmond, Victoria. 3121. Consumer Advisory Service - 1300 135 312. Mattel South Africa (PTY) LTD, Office 102 I3, 30 Melrose Boulevard, Johannesburg 2196. Mattel East Asia Ltd., Room 503-09, North Tower, World Finance Centre, Harbour City, Tsimshatsui, HK, China. Tel.: (852) 3185-6500. Diimport & Diedarkan Oleh: Mattel Southeast Asia Pte. Ltd., No 19-1, Tower 3 Avenue 7, Bangsar South City, No 8, Jalan Kerinchi, 59200 Kuala Lumpur, Malaysia. Tel: 03-33419052.

CONTENTS

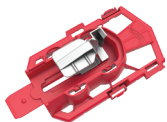

x2



x2

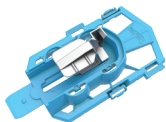

x2



x5



x5



x4



x2



x2

ASSEMBLY

1 ONE-TIME ASSEMBLY

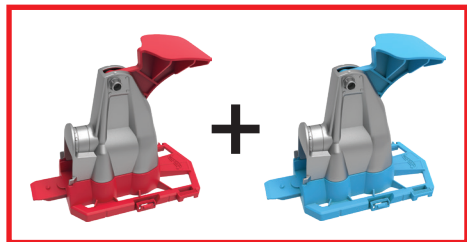
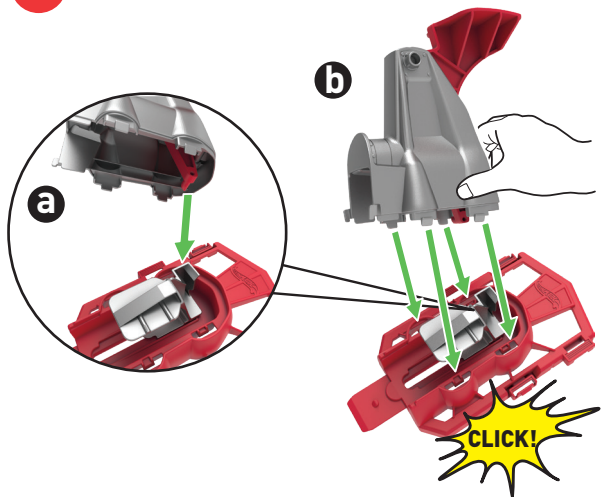

2

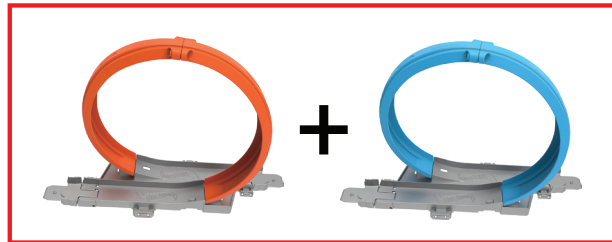
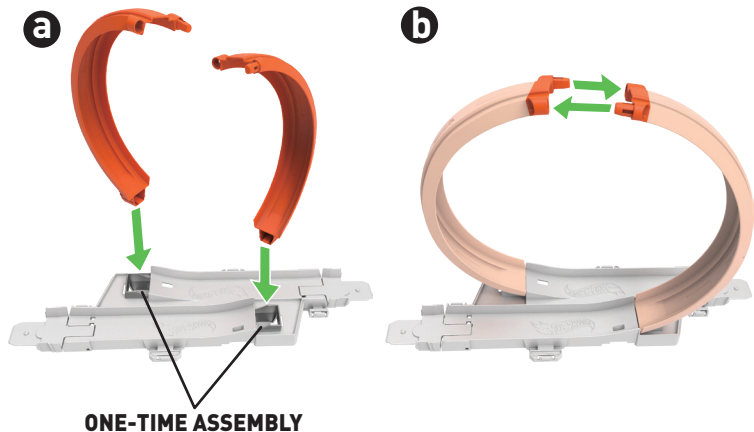

HEAD-TO-HEAD DRAG RACE

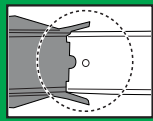

**NOTE: TRACK SHOULD GO INSIDE EACH TAB.
* ADJUST SIDE WALLS TO KEEP ALL TRACKS STRAIGHT BEFORE PLAY.**

SET-UP

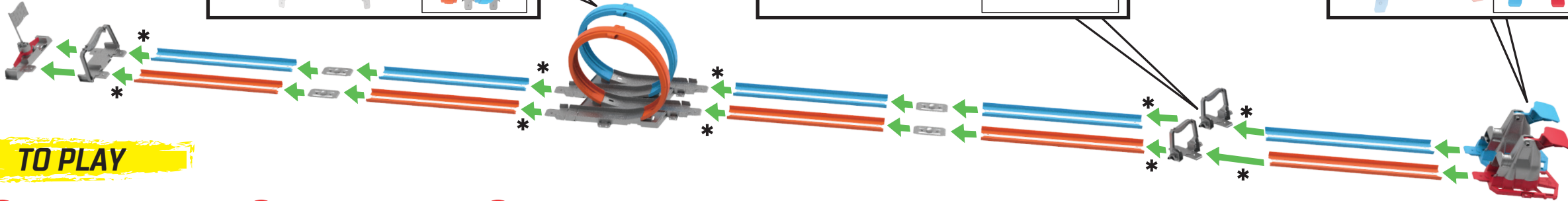
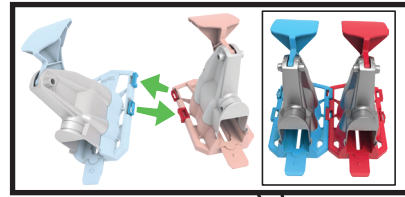
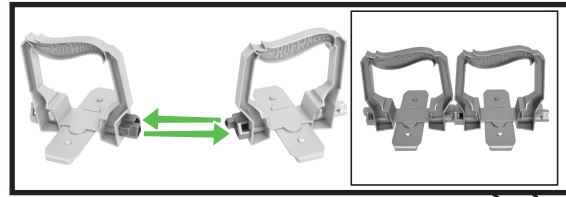
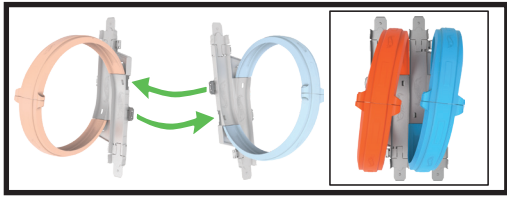

TO PLAY

1 CENTER THE FLAG BEFORE EACH RACE.

2 LOAD YOUR CARS INTO LAUNCHERS.

3 SLAM TO LAUNCH AND RACE HEAD-TO-HEAD! WINNER SPEEDS THROUGH THE LOOP AND TAKES THE FLAG!

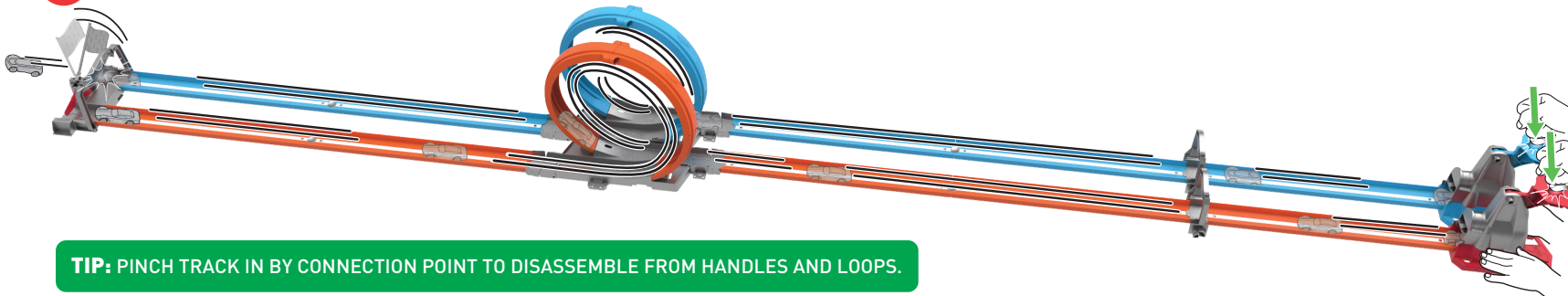
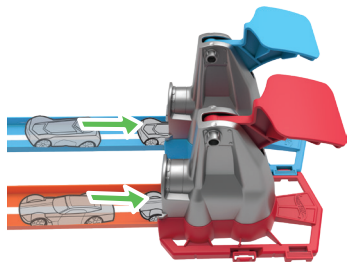
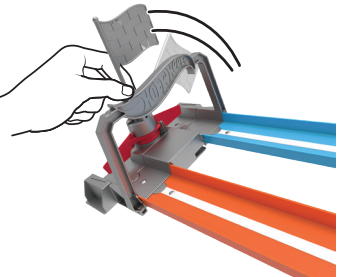

TIP: PINCH TRACK IN BY CONNECTION POINT TO DISASSEMBLE FROM HANDLES AND LOOPS.

LONG DISTANCE LOOP CHALLENGE

SET-UP

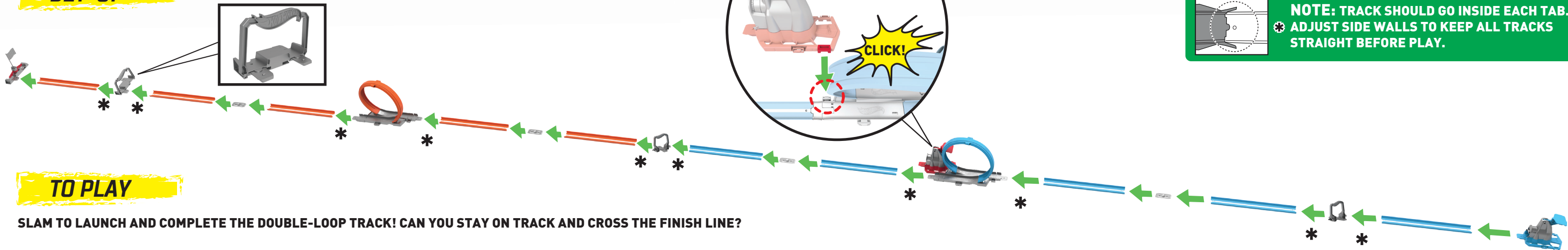

TO PLAY

SLAM TO LAUNCH AND COMPLETE THE DOUBLE-LOOP TRACK! CAN YOU STAY ON TRACK AND CROSS THE FINISH LINE?

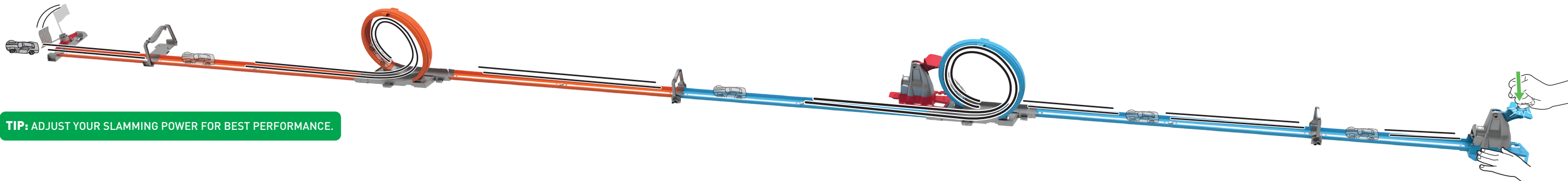

TIP: ADJUST YOUR SLAMMING POWER FOR BEST PERFORMANCE.

FOLD & GO

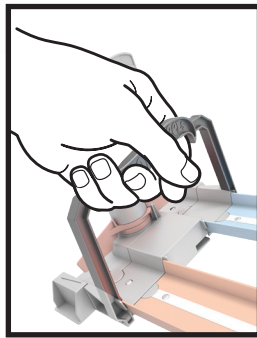

USE THE GATES AS GRAB HANDLES TO FOLD THE TRACK.

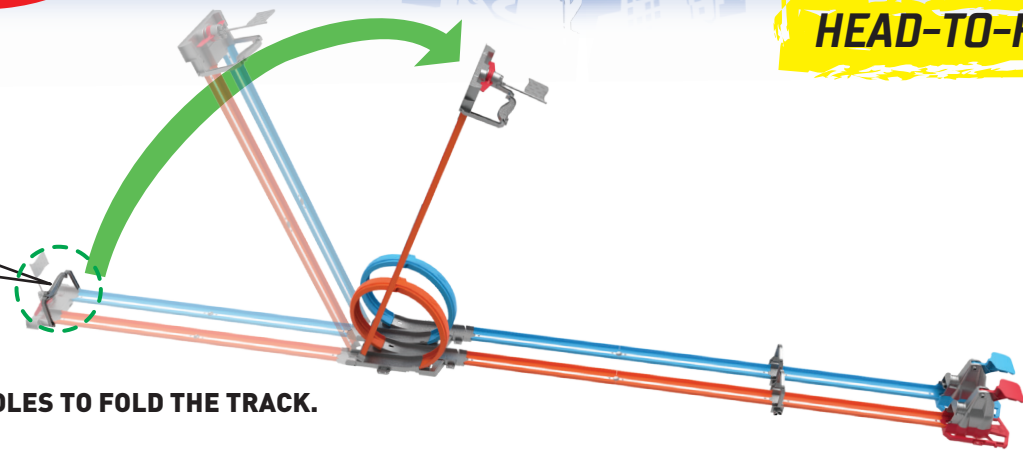

HEAD-TO-HEAD DRAG RACE

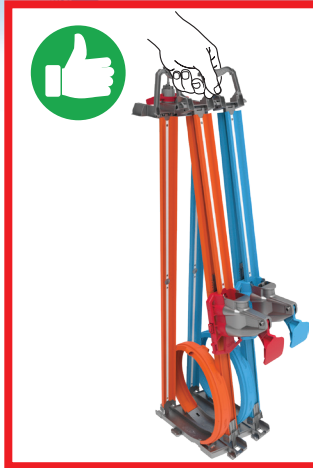
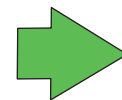
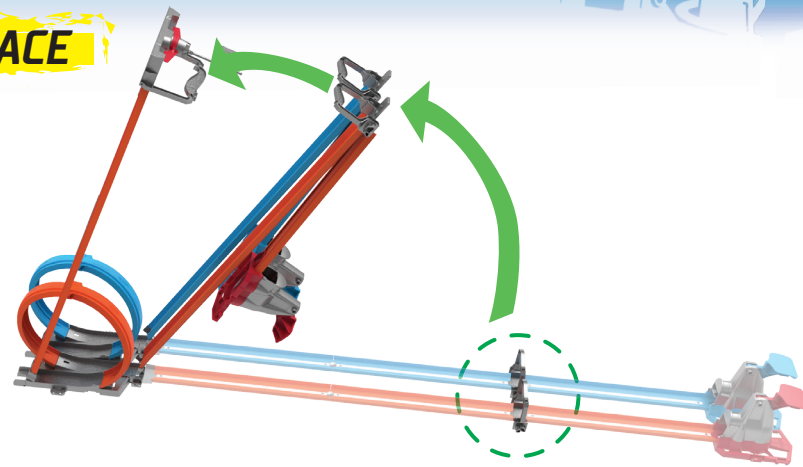

LONG DISTANCE LOOP CHALLENGE

